

High-Voltage, High-Current OPERATIONAL AMPLIFIERS

FEATURES

- **WIDE SUPPLY RANGE:** $\pm 4V$ to $\pm 30V$
- **HIGH OUTPUT CURRENT:** 200mA Continuous
- **LOW NOISE:** $14nV/\sqrt{Hz}$
- **FULLY PROTECTED:**
Thermal Shutdown
Output Current-Limited
- **THERMAL SHUTDOWN INDICATOR**
- **WIDE OUTPUT SWING:** 2V From Rail
- **FAST SLEW RATE:**
OPA551: $15V/\mu s$
OPA552: $24V/\mu s$
- **WIDE BANDWIDTH:**
OPA551: 3MHz
OPA552: 12MHz
- **PACKAGES:** DIP-8, SO-8, or DDPAK-7

APPLICATIONS

- TELEPHONY
- TEST EQUIPMENT
- AUDIO AMPLIFIERS
- TRANSDUCER EXCITATION
- SERVO DRIVERS

DESCRIPTION

The OPA551 and OPA552 are low cost op amps with high-voltage (60V) and high-current (200mA) capability.

The OPA551 is unity-gain stable and features high slew rate ($15V/\mu s$) and wide bandwidth (3MHz). The OPA552 is optimized for gains of 5 or greater, and offers higher speed with a slew rate of $24V/\mu s$ and a bandwidth of 12MHz. Both are suitable for telephony, audio, servo, and test applications.

These laser-trimmed, monolithic integrated circuits provide excellent low-level accuracy along with high output swing. High performance is maintained as the amplifier swings to its specified limits.

The OPA551 and OPA552 are internally protected against over-temperature conditions and current overloads. The thermal shutdown indicator “flag” provides a current output to alert the user when thermal shutdown has occurred.

The OPA551 and OPA552 are available in DIP-8 and SO-8 packages, as well as a DDPAK-7 surface-mount plastic power package. They are specified for operation over the extended industrial temperature range, $-40^{\circ}C$ to $+125^{\circ}C$.

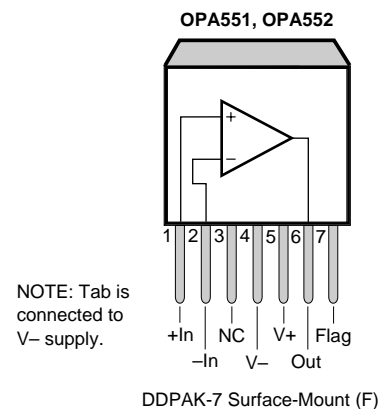
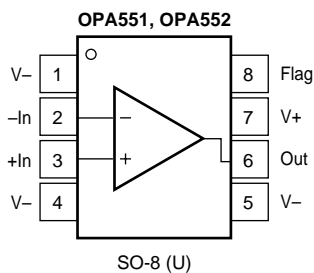
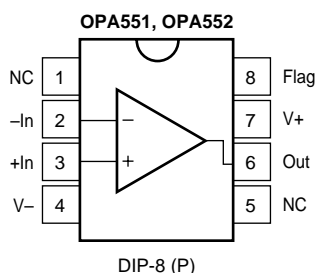

Please be aware that an important notice concerning availability, standard warranty, and use in critical applications of Texas Instruments semiconductor products and disclaimers thereto appears at the end of this data sheet.

All trademarks are the property of their respective owners.

SPECIFICATIONS: $V_S = \pm 30V$

OPA551

At $T_J = +25^\circ\text{C}$ (1), $R_L = 3\text{k}\Omega$ connected to ground and $V_{OUT} = 0V$, unless otherwise noted.

Boldface limits apply over the specified junction temperature range, $T_J = -40^\circ\text{C}$ to $+125^\circ\text{C}$.

PARAMETER	CONDITION	OPA551UA, PA, FA			UNITS
		MIN	TYP	MAX	
OFFSET VOLTAGE Input Offset Voltage V_{OS} $T_J = -40^\circ\text{C}$ to $+125^\circ\text{C}$ vs Temperature dV_{OS}/dT vs Power Supply PSRR	$V_{CM} = 0V, I_O = 0$ $V_S = \pm 4V$ to $\pm 30V, V_{CM} = 0V$		± 1	± 3	mV
			± 7	± 5	mV
			10	30	$\mu\text{V}/^\circ\text{C}$ $\mu\text{V}/V$
INPUT BIAS CURRENT Input Bias Current I_B Input Offset Current I_{OS}			± 20 ± 3	± 100 ± 100	pA pA
NOISE Input Voltage Noise Density, $f = 1\text{kHz}$ e_n Current Noise Density, $f = 1\text{kHz}$ i_n			14 3.5		$\text{nV}/\sqrt{\text{Hz}}$ $\text{fA}/\sqrt{\text{Hz}}$
INPUT VOLTAGE RANGE Common-Mode Voltage Range V_{CM} Common-Mode Rejection Ratio CMRR	$-27.5V < V_{CM} < +27.5V$		$(V-) + 2.5$ 92	$(V+) - 2.5$	V dB
				102	
INPUT IMPEDANCE Differential Common-Mode			$10^{13} \parallel 2$ $10^{13} \parallel 6$		$\Omega \parallel \text{pF}$ $\Omega \parallel \text{pF}$
OPEN-LOOP GAIN Open-Loop Voltage Gain A_{OL} $T_J = -40^\circ\text{C}$ to $+125^\circ\text{C}$	$R_L = 3\text{k}\Omega, -28V < V_O < +28V$ $R_L = 3\text{k}\Omega, -28V < V_O < +28V$ $R_L = 300\Omega, -27V < V_O < +27V$		110 100	126 120	dB dB dB
FREQUENCY RESPONSE Gain-Bandwidth Product GBW Slew Rate SR Settling Time: 0.1% 0.01% Total Harmonic Distortion + Noise, $f = 1\text{kHz}$ THD+N Overload Recovery Time	$G = 1$ $G = 1, C_L = 100\text{pF}, 10V$ Step $G = 1, C_L = 100\text{pF}, 10V$ Step $V_O = 15V_{\text{rms}}, R_L = 3\text{k}\Omega, G = 3$ $V_O = 15V_{\text{rms}}, R_L = 300\Omega, G = 3$ $V_{IN} \cdot \text{Gain} = V_S$		3 ± 15 1.3 2 0.0005 0.0005 1		MHz V/ μs μs μs % % μs
OUTPUT Voltage Output V_{OUT} $T_J = -40^\circ\text{C}$ to $+125^\circ\text{C}$ $T_J = -40^\circ\text{C}$ to $+125^\circ\text{C}$ Maximum Continuous Current Output: dc I_O Short-Circuit Current I_{SC} Capacitive Load Drive C_{LOAD}	Stable Operation		$(V-) + 3.0$ $(V-) + 3.5$ $(V-) + 2.0$ $(V-) + 2.5$ ± 200	$(V+) - 3.0$ $(V+) - 3.5$ $(V+) - 2.0$ $(V+) - 2.7$	V V V V mA mA
SHUTDOWN FLAG Thermal Shutdown Status Output Normal Operation Thermally Shutdown Voltage Compliance Range Junction Temperature Shutdown Reset from Shutdown	Sourcing Sourcing		80 V-	0.05 120 1 160 $(V+) - 1.5$	μA μA V $^\circ\text{C}$ $^\circ\text{C}$
POWER SUPPLY Specified Voltage V_S Operating Voltage Range Quiescent Current I_Q $T_J = -40^\circ\text{C}$ to $+125^\circ\text{C}$	$I_O = 0$		± 4	± 30 ± 30 ± 8.5 ± 10	V V mA mA
TEMPERATURE RANGE Specified Range T_J Operating Range T_J Storage Range T_A Thermal Resistance SO-8 Surface Mount θ_{JA} DIP-8 θ_{JA} DDPak-7 θ_{JA} DDPak-7 θ_{JC}			-40 -55 -65	+125 +125 +150	$^\circ\text{C}$ $^\circ\text{C}$ $^\circ\text{C}$

NOTES: (1) All tests are high-speed tested at $+25^\circ\text{C}$ ambient temperature. Effective junction temperature is $+25^\circ\text{C}$ unless otherwise noted.

SPECIFICATIONS: $V_S = \pm 30V$

OPA552

At $T_J = +25^\circ\text{C}^{(1)}$, $R_L = 3\text{k}\Omega$ connected to Ground and $V_{OUT} = 0V$, unless otherwise noted.

Boldface limits apply over the specified junction temperature range, $T_J = -40^\circ\text{C}$ to $+125^\circ\text{C}$.

PARAMETER	CONDITION	OPA552UA, PA, FA			UNITS	
		MIN	TYP	MAX		
OFFSET VOLTAGE Input Offset Voltage $T_J = -40^\circ\text{C}$ to $+125^\circ\text{C}$ vs Temperature vs Power Supply	V_{OS}	$V_{CM} = 0V, I_O = 0$ $V_S = \pm 4V$ to $\pm 30V, V_{CM} = 0V$	± 1	± 3	mV	
	dV_{OS}/dT		± 7	± 5	mV/ $^\circ\text{C}$	
	PSRR		10	30	$\mu\text{V}/V$	
INPUT BIAS CURRENT Input Bias Current Input Offset Current	I_B		± 20	± 100	pA	
	I_{OS}		± 3	± 100	pA	
NOISE Input Voltage Noise Density, $f = 1\text{kHz}$ Current Noise Density, $f = 1\text{kHz}$	e_n		14		$\text{nV}/\sqrt{\text{Hz}}$	
	i_n		3.5		$\text{fA}/\sqrt{\text{Hz}}$	
INPUT VOLTAGE RANGE Common-Mode Voltage Range Common-Mode Rejection Ratio	V_{CM}	$-27.5V < V_{CM} < +27.5V$	$(V-) + 2.5$	$(V+) - 2.5$	V	
	CMRR		92	102	dB	
INPUT IMPEDANCE Differential Common-Mode			$10^{13} \parallel 2$		$\Omega \parallel \text{pF}$	
			$10^{13} \parallel 6$		$\Omega \parallel \text{pF}$	
OPEN-LOOP GAIN Open-Loop Voltage Gain $T_J = -40^\circ\text{C}$ to $+125^\circ\text{C}$	A_{OL}	$R_L = 3\text{k}\Omega, -28V < V_O < +28V$ $R_L = 3\text{k}\Omega, -28V < V_O < +28V$ $R_L = 300\Omega, -27V < V_O < +27V$	110	126	dB	
			100		dB	
				120		dB
FREQUENCY RESPONSE Gain-Bandwidth Product Slew Rate Settling Time: 0.1% 0.01% Total Harmonic Distortion + Noise, $f = 1\text{kHz}$ Overload Recovery Time	GBW	$G = 5$ $G = 5, C_L = 100\text{pF}, 10V$ Step $G = 5, C_L = 100\text{pF}, 10V$ Step $V_O = 15V_{\text{rms}}, R_L = 3\text{k}\Omega, G = 5$ $V_O = 15V_{\text{rms}}, R_L = 300\Omega, G = 5$ $V_{IN} \cdot \text{Gain} = V_S$	12		MHz	
	SR		± 24		V/ μs	
			2.2		μs	
			3		μs	
			0.0005		%	
			0.0005		%	
OUTPUT Voltage Output $T_J = -40^\circ\text{C}$ to $+125^\circ\text{C}$ $T_J = -40^\circ\text{C}$ to $+125^\circ\text{C}$ Maximum Continuous Current Output: dc Short-Circuit Current Capacitive Load Drive	V_{OUT}	Stable Operation	$(V-) + 3.0$	$(V+) - 3.0$	V	
			$(V-) + 3.5$	$(V+) - 3.5$	V	
			$I_O = 10\text{mA}$	$(V-) + 2.0$	$(V+) - 2.0$	V
			$I_O = 10\text{mA}$	$(V-) + 2.5$	$(V+) - 2.7$	V
			Package Dependent—See Text	± 200		mA
	I_{SC}		± 380		mA	
	C_{LOAD}		See Typical Curve			
SHUTDOWN FLAG Thermal Shutdown Status Output Normal Operation Thermally Shutdown Voltage Compliance Range Junction Temperature Shutdown Reset from Shutdown		Sourcing	80	0.05	μA	
		Sourcing	$V-$	120	μA	
				160	V	
					$(V+) - 1.5$	
				160	$^\circ\text{C}$	
				140	$^\circ\text{C}$	
POWER SUPPLY Specified Voltage Operating Voltage Range Quiescent Current $T_J = -40^\circ\text{C}$ to $+125^\circ\text{C}$	V_S	$I_O = 0$	± 4	± 30	V	
				± 7	± 30	V
	I_Q			± 8.5	± 10	mA
					mA	
TEMPERATURE RANGE Specified Range Operating Range Storage Range Thermal Resistance SO-8 Surface Mount DIP-8 DDPak-7 DDPak-7	T_J		-40		$^\circ\text{C}$	
	T_J		-55		$^\circ\text{C}$	
	T_A		-65		$^\circ\text{C}$	
					+125	$^\circ\text{C}$
					+125	$^\circ\text{C}$
					+150	$^\circ\text{C}$
	θ_{JA}				90	$^\circ\text{C}/W$
	θ_{JA}				100	$^\circ\text{C}/W$
θ_{JA}			65	$^\circ\text{C}/W$		
θ_{JC}			3	$^\circ\text{C}/W$		

NOTES: (1) All tests are high-speed tested at $+25^\circ\text{C}$ ambient temperature. Effective junction temperature is $+25^\circ\text{C}$ unless otherwise noted.

ABSOLUTE MAXIMUM RATINGS⁽¹⁾

Output Current	See SOA Curve
Supply Voltage, V+ to V-	60V
Input Voltage Range	(V-) - 0.5V to (V+) + 0.5V
Operating Temperature	-55°C to +125°C
Storage Temperature	-65°C to +150°C
Junction Temperature	+150°C
Lead Temperature (soldering 10s, DIP-8)	300°C
(soldering 3s, SO-8 and DPAK)	240°C
ESD Capability (Human Body Model)	3000V

NOTE: (1) Stresses above these ratings may cause permanent damage. Exposure to absolute maximum conditions for extended periods may degrade device reliability.



ELECTROSTATIC DISCHARGE SENSITIVITY

This integrated circuit can be damaged by ESD. Burr-Brown recommends that all integrated circuits be handled with appropriate precautions. Failure to observe proper handling and installation procedures can cause damage.

ESD damage can range from subtle performance degradation to complete device failure. Precision integrated circuits may be more susceptible to damage because very small parametric changes could cause the device not to meet its published specifications.

PACKAGE/ORDERING INFORMATION

For the most current package and ordering information, see the Package Ordering Addendum at the end of this data sheet.

TYPICAL PERFORMANCE CURVES

At $T_J = +25^\circ\text{C}$, $V_S = \pm 30\text{V}$ and $R_L = 3\text{k}\Omega$, unless otherwise noted.

All temperatures are junction temperatures unless otherwise noted. Refer to the Applications Information section to calculate junction temperatures from ambient temperatures for a specific configuration.

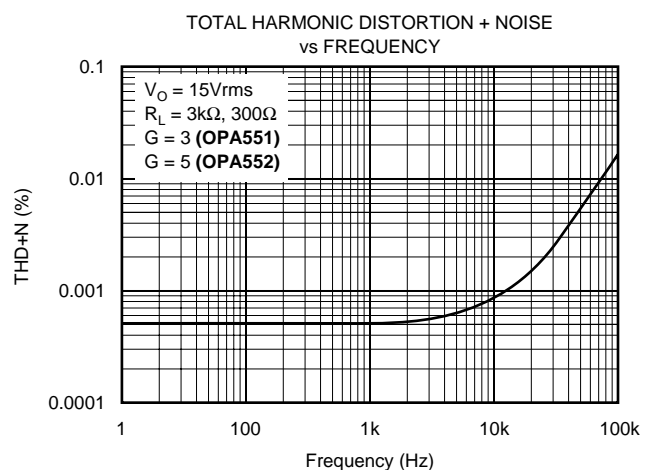
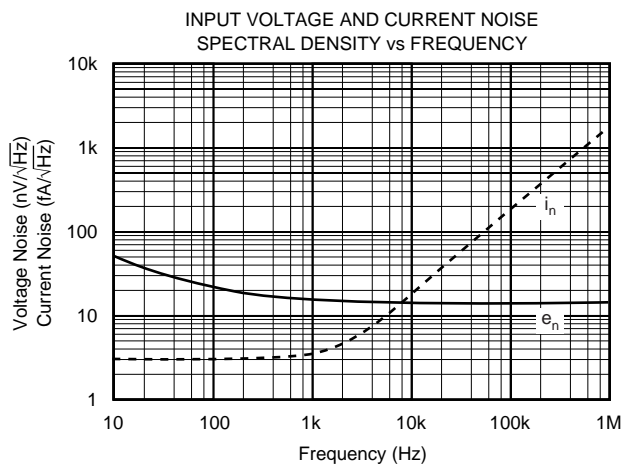
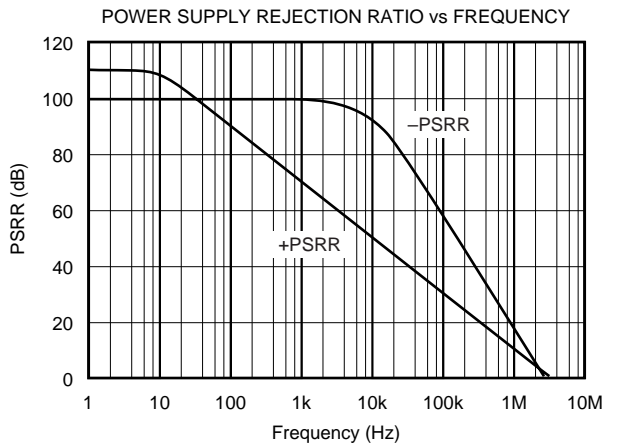
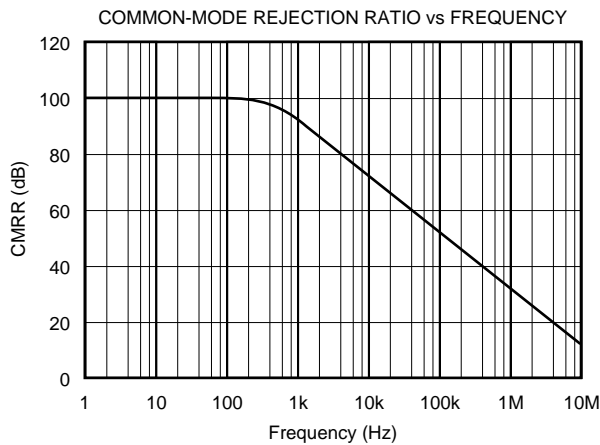
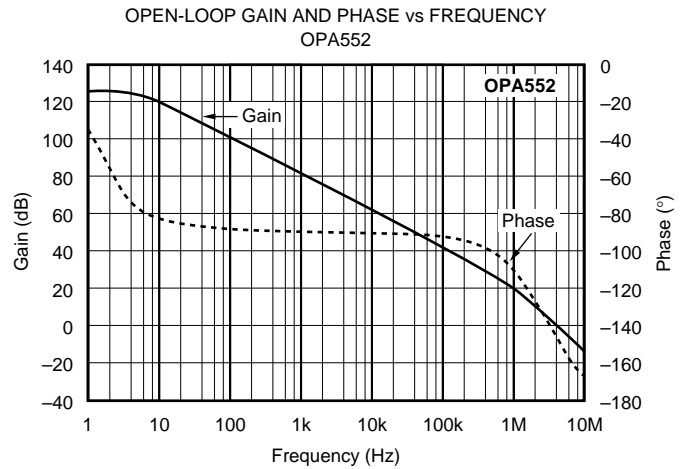
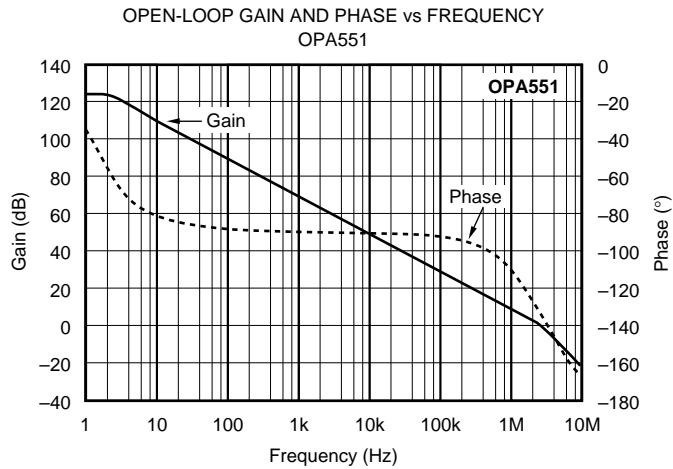

TYPICAL PERFORMANCE CURVES (Cont.)

At $T_J = +25^\circ\text{C}$, $V_S = \pm 30\text{V}$ and $R_L = 3\text{k}\Omega$, unless otherwise noted.

All temperatures are junction temperatures unless otherwise noted. Refer to the Applications Information section to calculate junction temperatures from ambient temperatures for a specific configuration.

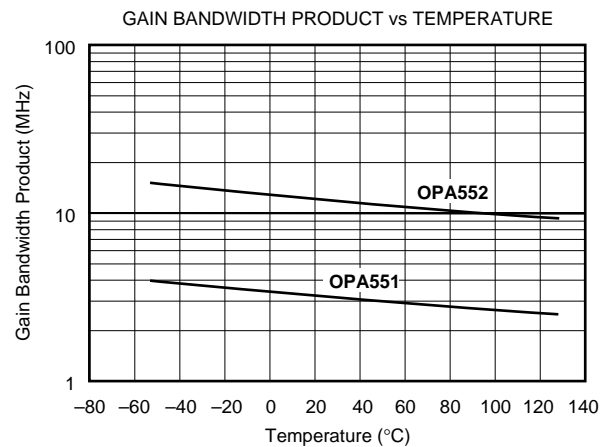
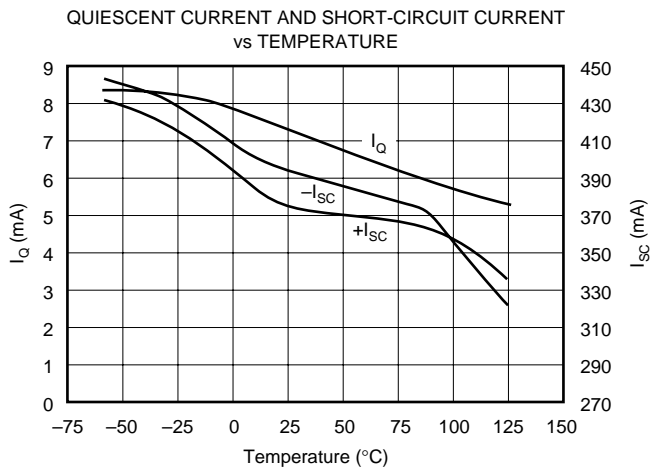
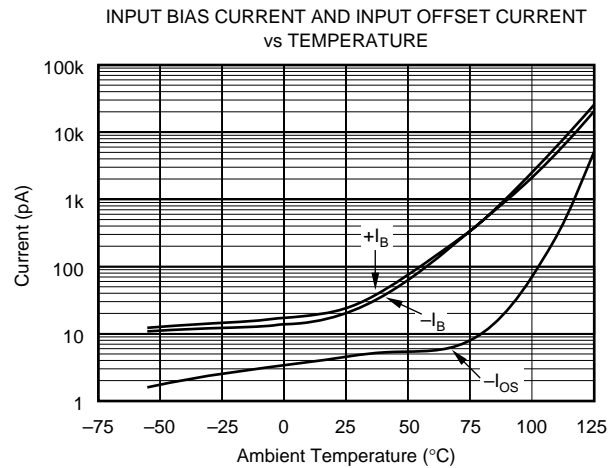
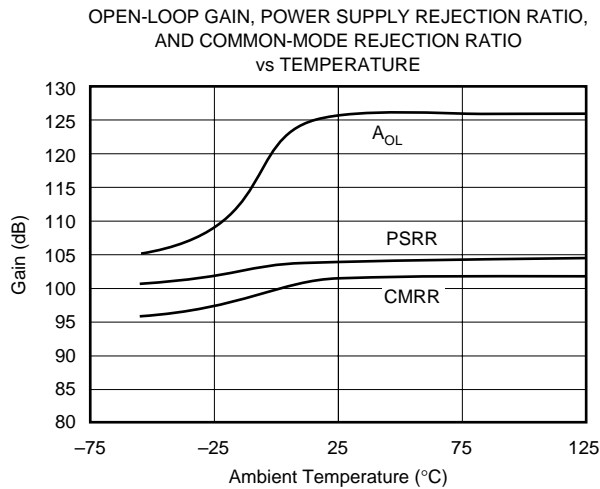
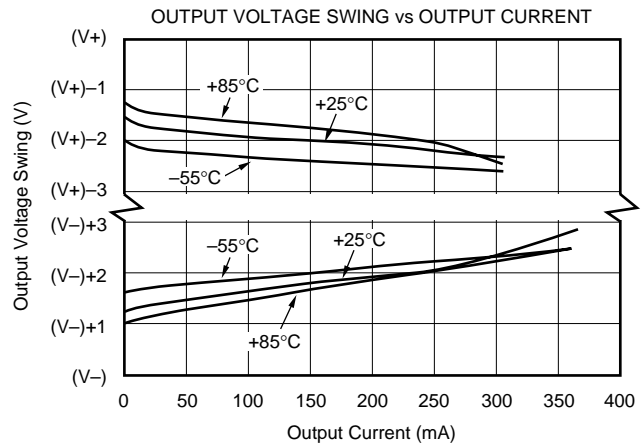
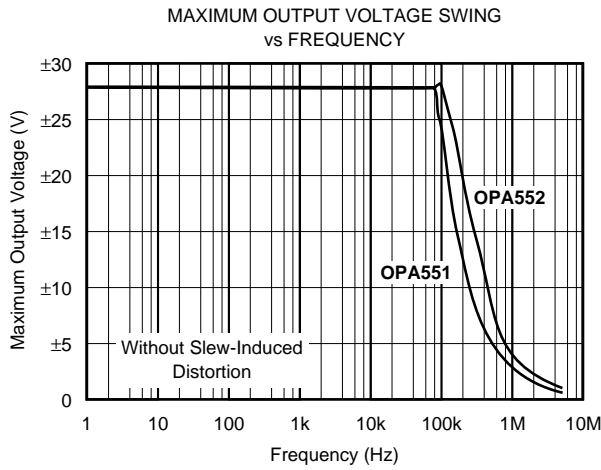

TYPICAL PERFORMANCE CURVES (Cont.)

At $T_J = +25^\circ\text{C}$, $V_S = \pm 30\text{V}$ and $R_L = 3\text{k}\Omega$, unless otherwise noted.

All temperatures are junction temperatures unless otherwise noted. Refer to the Applications Information section to calculate junction temperatures from ambient temperatures for a specific configuration.

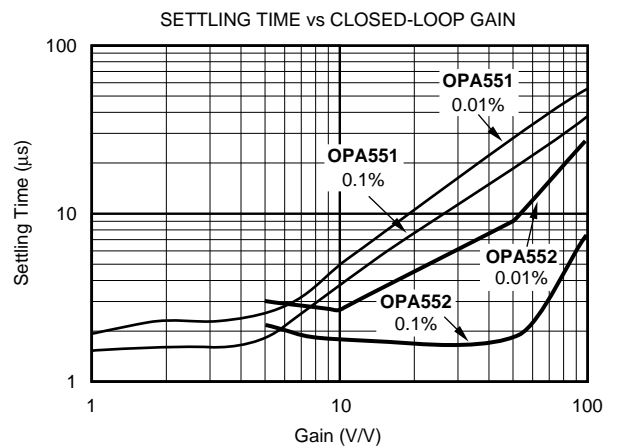
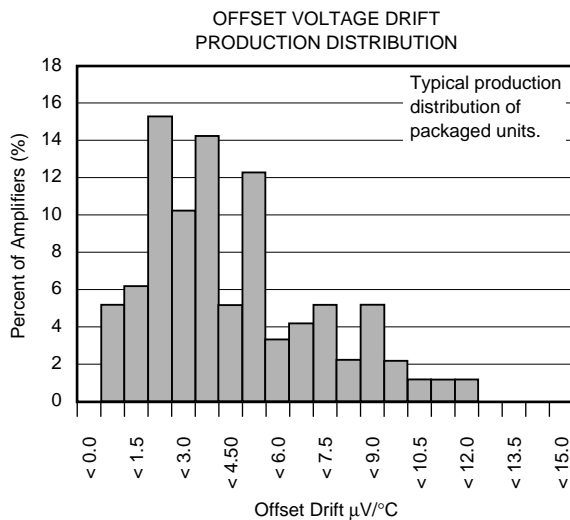
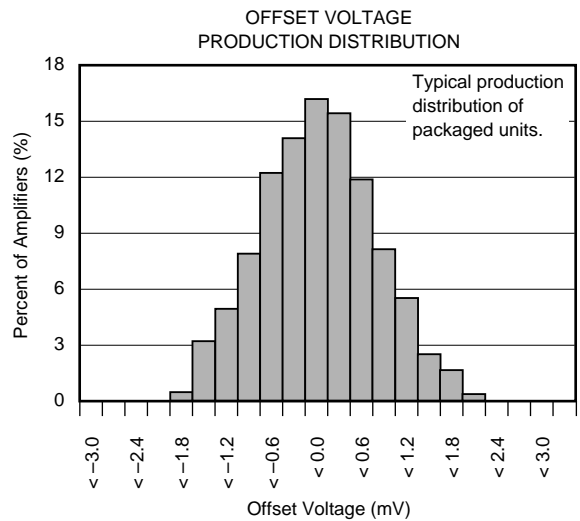
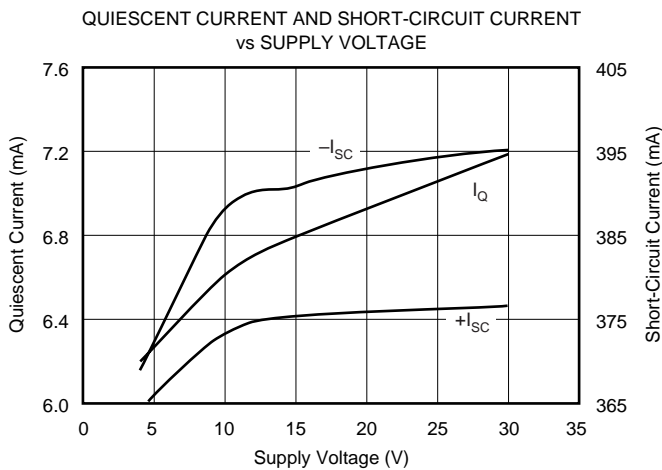
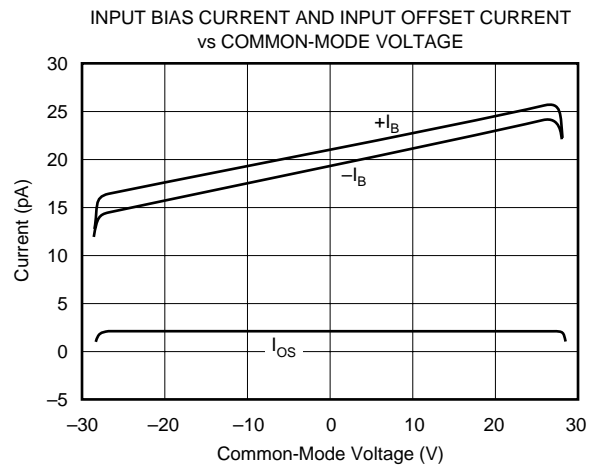
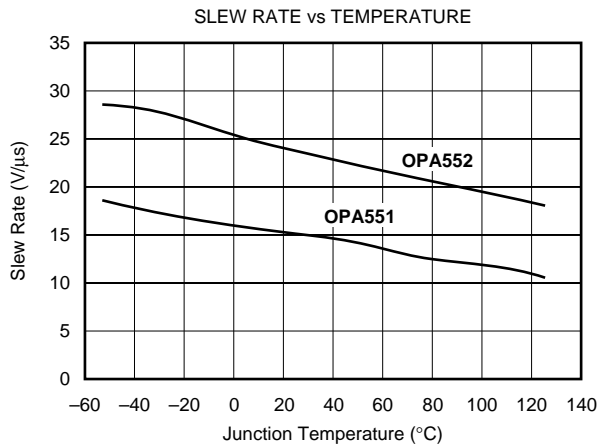

TYPICAL PERFORMANCE CURVES (Cont.)

At $T_J = +25^\circ\text{C}$, $V_S = \pm 30\text{V}$ and $R_L = 3\Omega$, unless otherwise noted.

All temperatures are junction temperatures unless otherwise noted. Refer to the Applications Information section to calculate junction temperatures from ambient temperatures for a specific configuration.

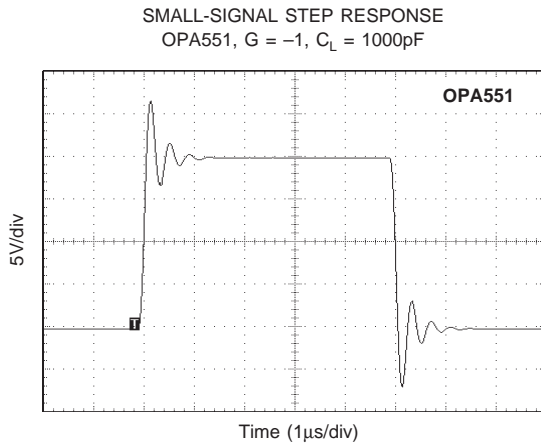
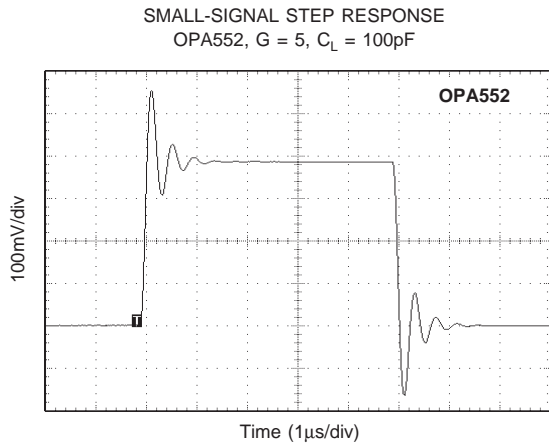
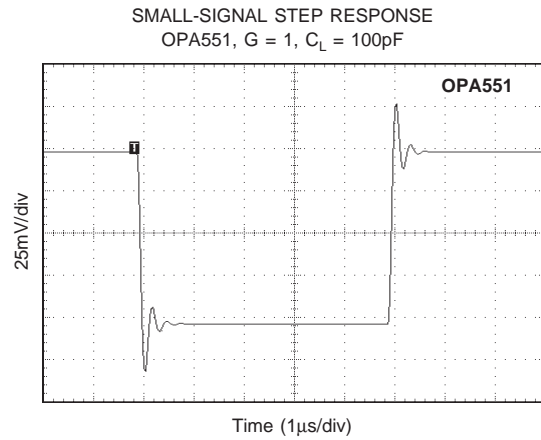
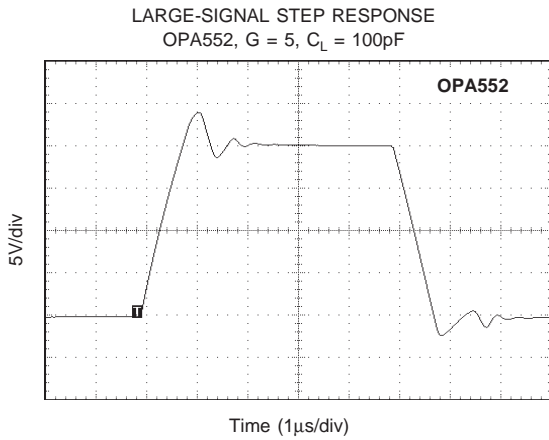
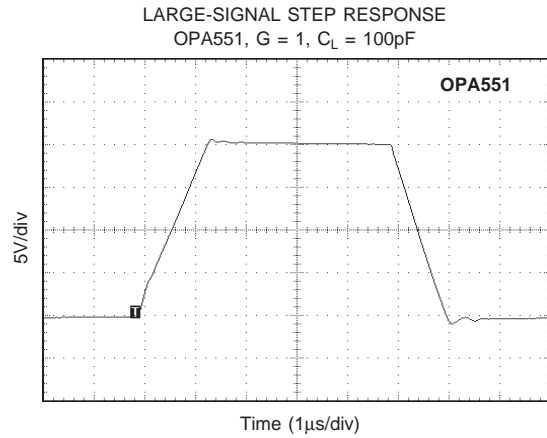
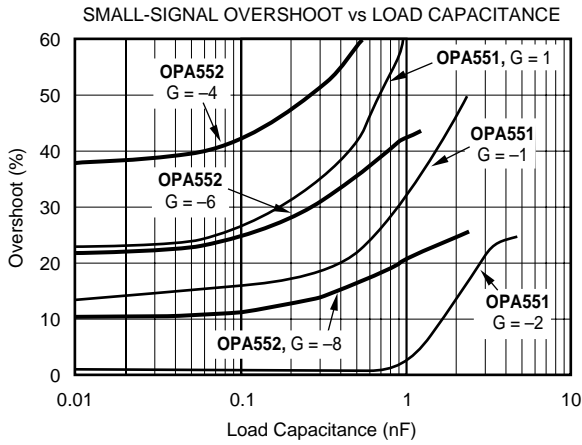

APPLICATIONS INFORMATION

Figure 1 shows the OPA551 connected as a basic non-inverting amplifier. The OPA551 can be used in virtually any op amp configuration. OPA552 is designed for use in configurations with gains of 5 or greater. Power supply terminals should be bypassed with 0.1µF capacitors, or greater, near the power supply pins. Be sure that the capacitors are appropriately rated for the power supply voltage used. The OPA551 and OPA552 can supply output currents up to 200mA with excellent performance.

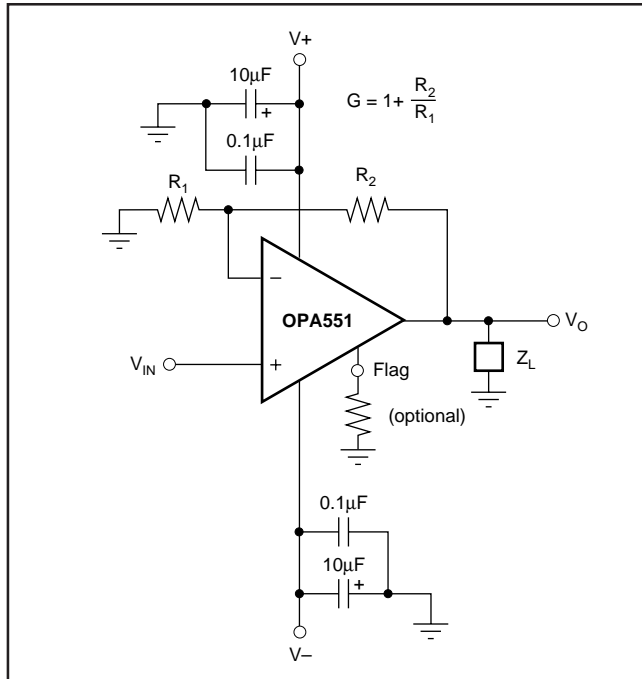

FIGURE 1. Basic Circuit Connections.

CURRENT LIMIT

The OPA551 and OPA552 are designed with internal current-limiting circuitry that limits the output current to approximately 380mA. The current limit varies with increasing junction temperature as shown in the typical curve “Current Limit vs Temperature.” This, in combination with the thermal protection circuitry, provides protection from many types of overload conditions including short circuit to ground.

THERMAL PROTECTION

The OPA551 and OPA552 have thermal shutdown circuitry that protects the amplifier from damage caused by overload conditions. The thermal protection circuitry disables the output when the junction temperature reaches approximately 160°C, allowing the device to cool. When the junction temperature cools to approximately 140°C, the output circuitry is automatically re-enabled.

The thermal shutdown function is not intended to replace proper heat sinking. Activation of the thermal shutdown circuitry is an indication of excessive power dissipation or an inadequate heat sink. Continuously running the amplifier into thermal shutdown can degrade reliability.

The Thermal Shutdown Indicator (“flag”) pin can be monitored to determine if shutdown is occurring. During normal operation, the current output from the flag pin is typically 50nA. During shutdown, the current output from the flag pin increases to 120µA (typical). This current output allows for easy interfacing to external logic. See Figure 2 for two examples implementing this function.

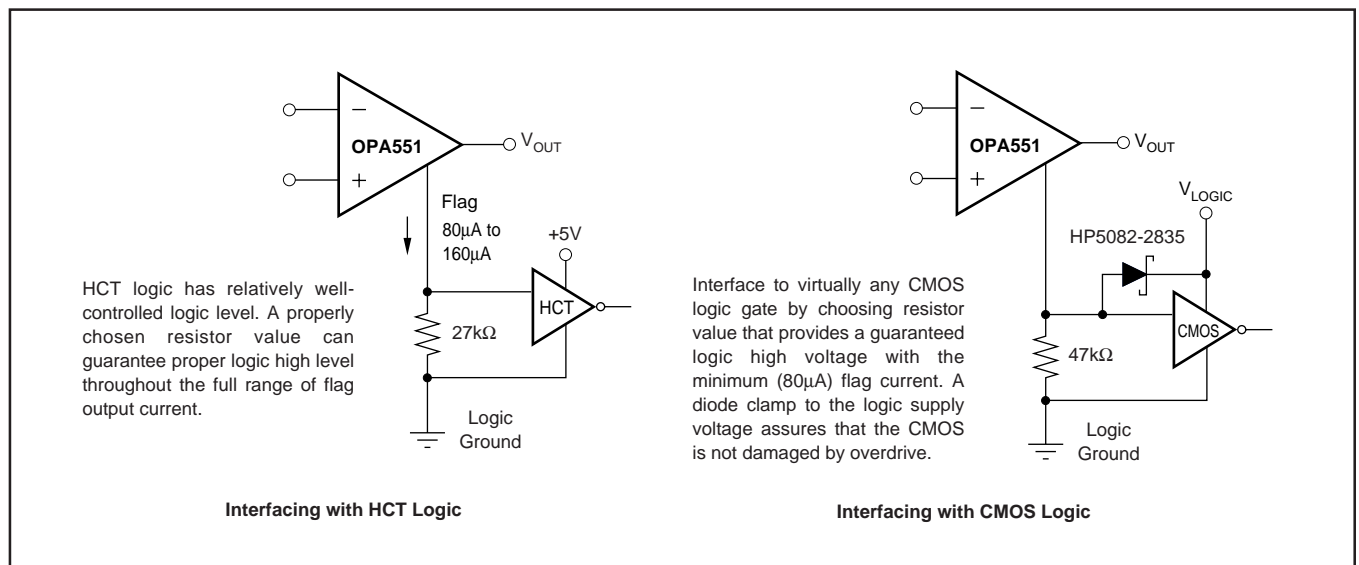

FIGURE 2. Thermal Shutdown Indicator.

POWER SUPPLIES

The OPA551 and OPA552 may be operated from power supplies of $\pm 4\text{V}$ to $\pm 30\text{V}$, or a total of 60V with excellent performance. Most behavior remains unchanged throughout the full operating voltage range. Parameters that vary significantly with operating voltage are shown in the Typical Performance Curves.

For applications that do not require symmetrical output voltage swing, power supply voltages do not need to be equal. The OPA551 and OPA552 can operate with as little as 8V between the supplies or with up to 60V between the supplies. For example, the positive supply could be set to 50V with the negative supply at -10V or vice-versa.

The SO-8 package outline shows three negative supply (V^-) pins. These pins are internally connected for improved thermal performance. **Pin 4 is to be used as the primary current carrier for the negative supply. It is recommended that pins 1 and 5 not be directly connected to V^- but, instead be connected to a thermal mass. DO NOT lay out the PC board to use pins 1 and 5 as feedthroughs to the negative supply. Doing so can result in a reduction of performance.**

The tab of the DDPAK-7 package is electrically connected to the negative supply (V^-), however, this connection should not be used to carry current. For best thermal performance, the tab should be soldered directly to the circuit board copper area (see heat sink text).

POWER DISSIPATION

Internal power dissipation of these op amps can be quite large. Many of the specifications for the OPA551 and OPA552 are for a specified junction temperature. If the device is not subjected to internal self-heating, the junction temperature will be the same as the ambient. However, in practical applications, the device will self-heat and the junction temperature will be significantly higher than ambient. After junction temperature has been established, performance parameters that vary with junction temperature can be determined from the performance curves. The following calculation can be performed to establish junction temperature as a function of ambient temperature and the conditions of the application.

Consider the OPA551 in a circuit configuration where the load is 600Ω and the output voltage is 15V . The supplies are at $\pm 30\text{V}$ and the ambient temperature (T_A) is 40°C . The θ_{JA} for the 8-pin DIP package is $100^\circ\text{C}/\text{W}$.

First, the internal heating of the op amp is as follows:

$$P_{D(\text{internal})} = I_Q \cdot V_S = 7.2\text{mA} \cdot 60\text{V} = 432\text{mW}$$

The output current (I_O) can be calculated:

$$I_O = V_{\text{OUT}}/R_L = 15\text{V}/600\Omega = 25\text{mA}$$

The power being dissipated (P_D) in the output transistor of the amplifier can be calculated:

$$P_{D(\text{output stage})} = I_O \cdot (V_S - V_O) = 25\text{mA} \cdot (30 - 15) = 375\text{mW}$$

$$P_{D(\text{total})} = P_{D(\text{internal})} + P_{D(\text{output stage})} = 432\text{mW} + 375\text{mW} = 807\text{mW}$$

The resulting junction temperature can be calculated:

$$T_J = T_A + P_D \theta_{JA}$$

$$T_J = 40^\circ\text{C} + 807\text{mW} \cdot 100^\circ\text{C}/\text{W} = 120.7^\circ\text{C}$$

Where,

T_J = junction temperature ($^\circ\text{C}$)

T_A = ambient temperature ($^\circ\text{C}$)

θ_{JA} = junction-to-air thermal resistance ($^\circ\text{C}/\text{W}$)

For the DDPAK package, the θ_{JA} is $65^\circ\text{C}/\text{W}$ with no heat sinking, resulting in a junction temperature of 92.5°C .

To estimate the margin of safety in a complete design (including heat sink), increase the ambient temperature until the thermal protection is activated. Use worst-case load and signal conditions. For good reliability, the thermal protection should trigger more than $+35^\circ\text{C}$ above the maximum expected ambient condition of your application. This ensures a maximum junction temperature of $+125^\circ\text{C}$ at the maximum expected ambient condition.

If the OPA551 or OPA552 is to be used in an application requiring more than 0.5W continuous power dissipation, it is recommended that the DDPAK package option be used. The DDPAK has superior thermal dissipation characteristics and is more easily adapted to a heat sink.

Operation from a single power supply (or unbalanced power supplies) can produce even larger power dissipation since a larger voltage can be impressed across the conducting output transistor. Consult Application Bulletin AB-039 for further information on how to calculate or measure power dissipation.

Power dissipation can be minimized by using the lowest possible supply voltage. For example, with a 200mA load, the output will swing to within 3.5V of the power supply rails. Power supplies set to no more than 3.5V above the maximum output voltage swing required by the application will minimize the power dissipation.

SAFE OPERATING AREA

The Safe Operating Area (SOA curves, Figures 3, 4, and 5) shows the permissible range of voltage and current. The curves shown represent devices soldered to a circuit board with no heat sink. The safe output current decreases as the voltage across the output transistor ($V_S - V_O$) increases. For further insight on SOA, consult Application Bulletin AB-039.

Output short circuits are a very demanding case for SOA. A short circuit to ground forces the full power supply voltage (V^+ or V^-) across the conducting transistor and produces a typical output current of 380mA . With $\pm 30\text{V}$

power supplies, this creates an internal dissipation of 11.4W. This far exceeds the maximum rating and is not recommended. If operation in this region is unavoidable, use the DDPAK with a heat sink.

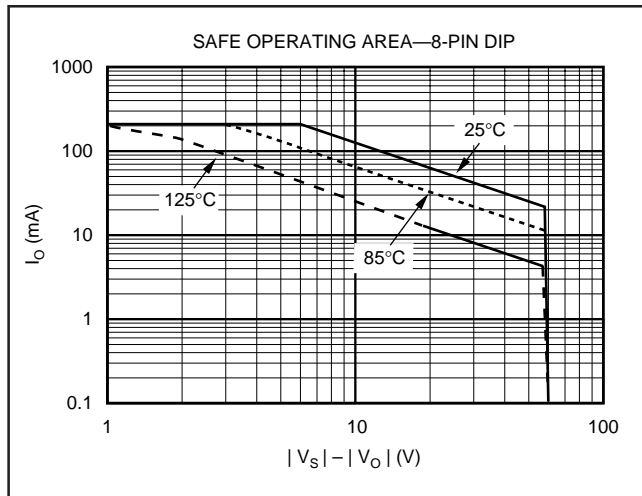

FIGURE 3. DIP-8 Safe Operating Area.

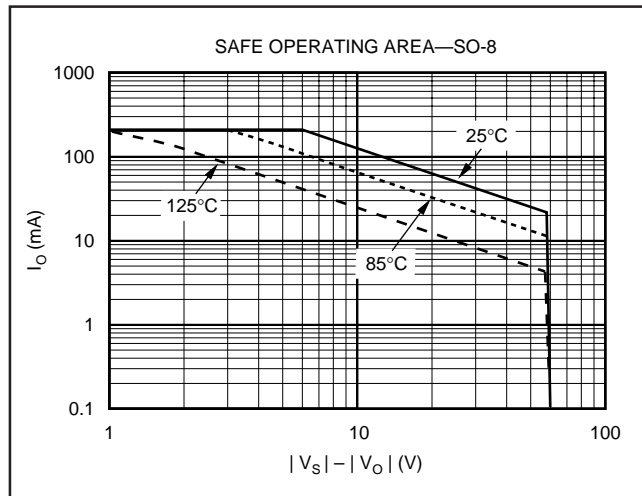

FIGURE 4. SO-8 Safe Operating Area.

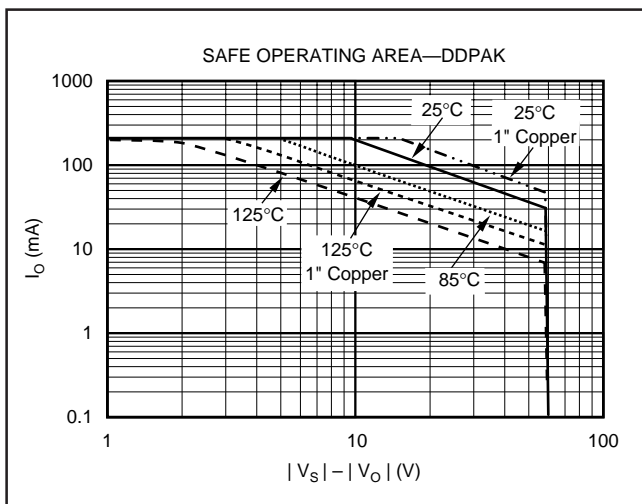

FIGURE 5. DDPAK-7 Safe Operating Area.

HEAT SINKING

Power dissipated in the OPA551 or OPA552 will cause the junction temperature to rise. For reliable operation, the junction temperature should be limited to +125°C. Many applications will require a heat sink to assure that the maximum operating junction temperature is not exceeded. The heat sink required depends on the power dissipated and on ambient conditions.

For heat sinking purposes, the tab of the DDPAK is typically soldered directly to a circuit board copper area. Increasing the copper area improves heat dissipation. Figure 6 shows typical thermal resistance from junction-to-ambient as a function of copper area.

Depending on conditions, additional heat sinking may be required. Aavid Thermal Products Inc. manufactures surface-mountable heat sinks designed specifically for use with DDPAK packages. Further information is available on Aavid's web site, www.aavid.com.

To estimate the margin of safety in a complete design (including heat sink), increase the ambient temperature until the thermal protection is activated. Use worst-case load and signal conditions. For good reliability, the thermal protection should trigger more than +25°C above the maximum expected ambient condition of your application. This produces a junction temperature of +125°C at the maximum expected ambient condition.

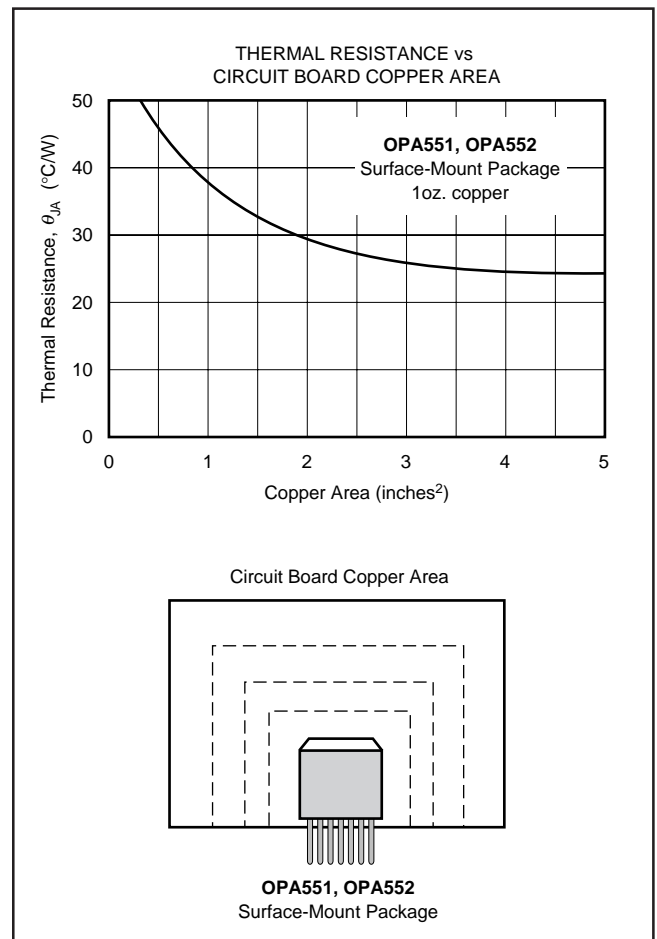

FIGURE 6. DDPAK Thermal Resistance vs Circuit Board Copper Area.

CAPACITIVE LOADS

The dynamic characteristics of the OPA551 and OPA552 have been optimized for commonly encountered gains, loads, and operating conditions. The combination of low closed-loop gain and capacitive load will decrease the phase margin and may lead to gain peaking or oscillations. Figure 7 shows a circuit that preserves phase margin with capacitive load. Figure 8 shows the small-signal step response for the circuit in Figure 7. Consult Application Bulletin AB-028 for more information.

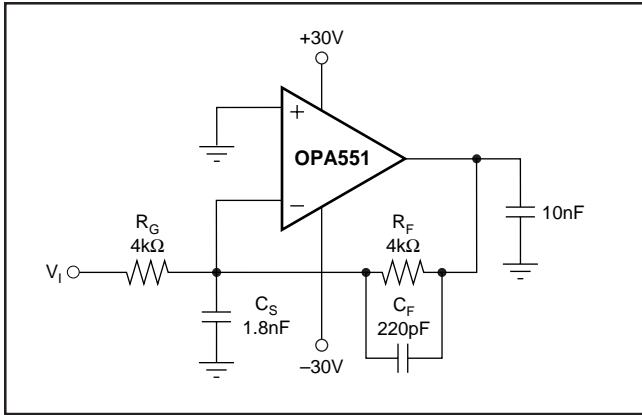

FIGURE 7. Driving Large Capacitive Loads.

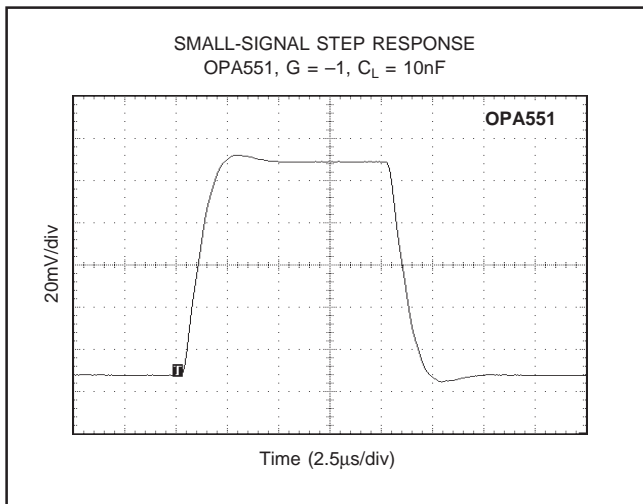

FIGURE 8. Small-Signal Step Response for Figure 7.

INCREASING OUTPUT CURRENT

In those applications where the 200mA of output current is not sufficient to drive the desired load, output current can be increased by connecting two or more OPA551s or OPA552s in parallel as shown in Figure 9. Amplifier A1 is the “master” amplifier and may be configured in virtually an op amp circuit. Amplifier A2, the “slave”, is configured as a unity gain buffer. Alternatively, external output transistors

can be used to boost output current. The circuit in Figure 10 is capable of supplying output currents up to 1A. Alternatively, the OPA547, OPA548, and OPA549 series power op amps should be considered for high output current drive, along with programmable current limit and output disable capability.

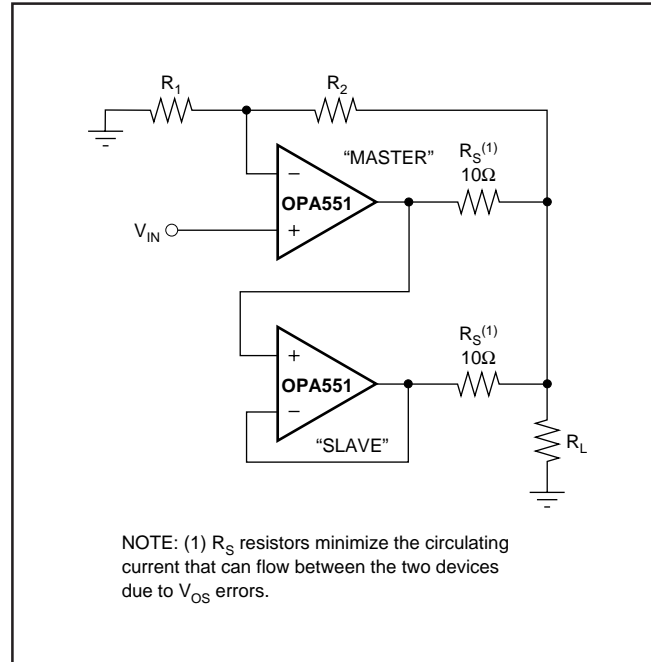

FIGURE 9. Parallel Amplifiers Increase Output Current Capability.

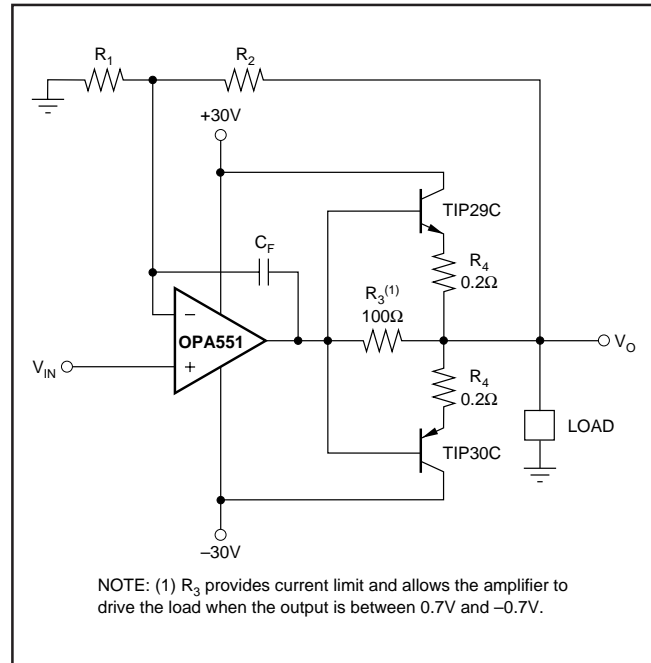

FIGURE 10. External Output Transistors Boost Output Current Up to 1 Amp.

INPUT PROTECTION

The OPA551 and OPA552 feature internal clamp diodes to protect the inputs when voltages beyond the supply rails are encountered. However, input current should be limited to 5mA. In some cases, an external series resistor may be required. Many input signals are inherently current-limited, therefore, a limiting resistor may not be required. Please consider that a “large” series resistor, in conjunction with the input capacitance, can affect stability.

USING THE OPA552 IN LOW GAINS

The OPA552 family is intended for applications with signal gains of 5 or greater, but it is possible to take advantage of their high slew rate in lower gains using an external compensation technique in an inverting configuration. This technique maintains low noise characteristics of the OPA552 architecture at low frequencies. Depending on the application, a small increase in high frequency noise may result. This technique shapes the loop gain for good stability while giving an easily controlled second-order low-pass frequency response.

Considering only the noise gain (non-inverting signal gain) for the circuit of Figure 11, the low frequency noise gain (NG_1) will be set by the resistor ratios, while the high frequency noise gain (NG_2) will be set by the capacitor ratios. The capacitor values set both the transition frequencies and the high frequency noise gain. If this noise gain, determined by $NG_2 = 1 + C_S/C_F$, is set to a value greater than the recommended minimum stable gain for the op amp and the noise gain pole, set by $1/R_F C_F$, is placed correctly, a very well controlled, 2nd-order low-pass frequency response will result.

To choose the values for both C_S and C_F , two parameters and only three equations need to be solved. First, the target for the high frequency noise gain (NG_2) should be greater than the minimum stable gain for the OPA552. In the circuit in Figure 11, a target NG_2 of 10 is used. Second, the signal gain of -1 shown in Figure 11 sets the low frequency noise gain to $NG_1 = 1 + R_F/R_G$ ($=2$ in this example). Using these two gains, knowing the Gain Bandwidth Product (GBP) for the OPA552 (12MHz), and targeting a maximally flat 2nd-order, low-pass Butterworth frequency response ($Q = 0.707$), the key frequency in the compensation can be found.

For the values shown in Figure 11, the f_{-3dB} will be approximately 956kHz. This is less than that predicted by simply dividing the GBP by NG_1 . The compensation network controls the bandwidth to a lower value while

providing the full slew rate at the output and an exceptional distortion performance due to increased loop gain at frequencies below $NG_1 \cdot Z_0$. The capacitor values shown in Figure 11 are calculated for $NG_1 = 2$ and $NG_2 = 10$ with no adjustment for parasitics.

Actual circuit values can be optimized by check the small-signal step response with actual load conditions. Figure 12 shows the small-signal step response of this OPA552, $G = -1$ circuit with a 500pF load. It is well-behaved with no tendency to oscillate. If C_S and C_F were removed, the circuit would be unstable.

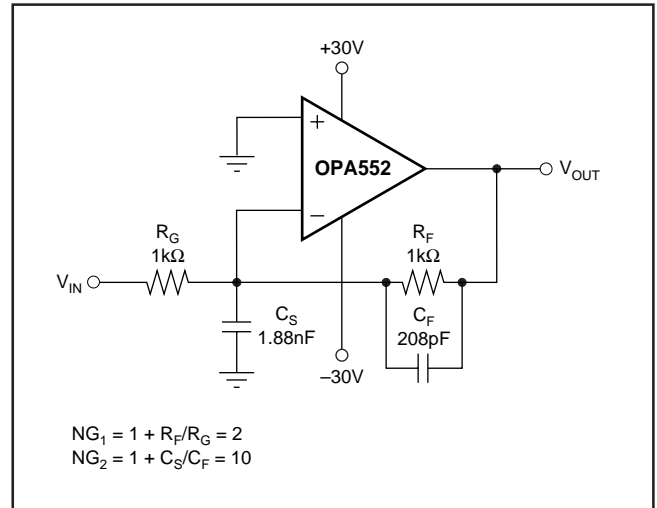

FIGURE 11. Compensation of the OPA552 for $G = 1$.

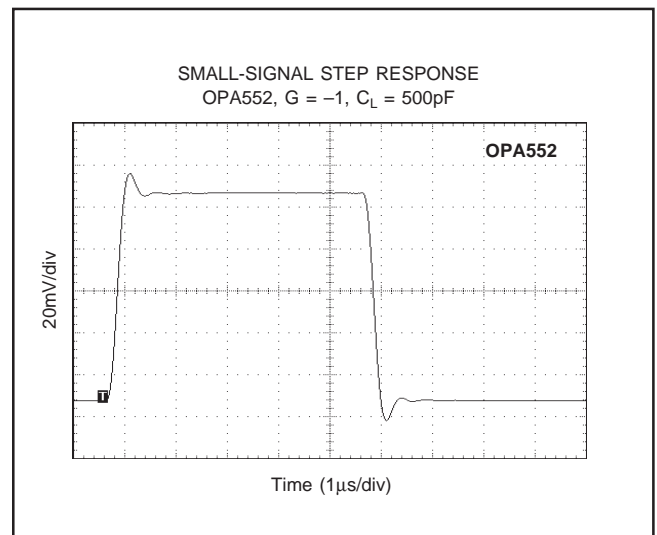

FIGURE 12. Small-Signal Step Response for Figure 11.

OFFSET VOLTAGE ERROR CALCULATION

The offset voltage (V_{OS}) of the OPA51 and OPA552 is specified with a $\pm 30V$ power supply and the common-mode voltage centered between the supplies ($V_S/2 = 0V$). Additional specifications for power supply rejection and common-mode rejection are provided to allow the user to easily calculate worst-case expected offset under the conditions of a given application.

Power Supply Rejection Ratio (PSRR) is specified in $\mu V/V$. For the OPA551 and OPA552, worst-case PSRR is $30\mu V/V$, which means for each volt of change in total power supply voltage, the offset may shift by up to $30\mu V/V$. Common-Mode Rejection Ratio (CMRR) is specified in dB, which can be converted to $\mu V/V$ using the following equation:

$$\text{CMRR in (V/V)} = 10^{[(\text{CMRR in dB})/-20]} \quad (1)$$

For the OPA551 and OPA552, the worst-case CMRR at $\pm 30mV$ supply over the full common-mode range is 96dB, or approximately $15.8\mu V/V$. This means that for every volt of change in common-mode, the offset may shift up to $15.8\mu V$. These numbers can be used to

calculate excursions from the specified offset voltage under different applications conditions. For example, a common application might configure the amplifier with a -48 single supply with $-6V$ common-mode. This configuration represents a 12V variation in power supply: $\pm 30V$ or 60V in the offset specification versus 48V in the application. In addition, this configuration has an 18V variation in common-mode voltage: $V_S/2 = -24V$ is the specification for these power supplies, but the common-mode voltage is $-6V$ in the application.

Calculation of the worst-case expected offset would be as follows:

$$\begin{aligned} \text{Worst-case } V_{OS} = & \quad (2) \\ & \text{maximum specified } V_{OS} \\ & + (\text{power supply variation} \cdot \text{PSRR}) \\ & + (\text{common-mode variation} \cdot \text{CMRR}) \end{aligned}$$

$$\begin{aligned} V_{OSwc} &= 5mV + (12V \cdot 30\mu V/V) + (18V \cdot 15.8\mu V/V) \\ &= \pm 5.64mV \end{aligned}$$

PACKAGING INFORMATION

Orderable Device	Status ⁽¹⁾	Package Type	Package Drawing	Pins	Package Qty	Eco Plan ⁽²⁾	Lead/Ball Finish	MSL Peak Temp ⁽³⁾
OPA551FA	OBSOLETE	DDPAK	KTW	7		TBD	Call TI	Call TI
OPA551FA/500	ACTIVE	DDPAK	KTW	7	500	Green (RoHS & no Sb/Br)	CU SN	Level-2-260C-1 YEAR
OPA551FA/500G3	ACTIVE	DDPAK	KTW	7	500	Green (RoHS & no Sb/Br)	CU SN	Level-2-260C-1 YEAR
OPA551FAKTWT	ACTIVE	DDPAK	KTW	7	50	Green (RoHS & no Sb/Br)	CU SN	Level-2-260C-1 YEAR
OPA551FAKTWTG3	ACTIVE	DDPAK	KTW	7	50	Green (RoHS & no Sb/Br)	CU SN	Level-2-260C-1 YEAR
OPA551PA	ACTIVE	PDIP	P	8	50	TBD	CU SNPB	Level-NA-NA-NA
OPA551UA	ACTIVE	SOIC	D	8	100	Green (RoHS & no Sb/Br)	CU NIPDAU	Level-2-260C-1 YEAR
OPA551UA/2K5	ACTIVE	SOIC	D	8	2500	Green (RoHS & no Sb/Br)	CU NIPDAU	Level-2-260C-1 YEAR
OPA552FA	NRND	DDPAK	KTW	7	49	TBD	Call TI	Call TI
OPA552FA/500	ACTIVE	DDPAK	KTW	7	500	Green (RoHS & no Sb/Br)	CU SN	Level-2-260C-1 YEAR
OPA552FAKTWT	ACTIVE	DDPAK	KTW	7	50	Green (RoHS & no Sb/Br)	CU SN	Level-2-260C-1 YEAR
OPA552PA	ACTIVE	PDIP	P	8	50	TBD	CU SNPB	Level-NA-NA-NA
OPA552UA	ACTIVE	SOIC	D	8	100	TBD	CU NIPDAU	Level-3-220C-168 HR
OPA552UA/2K5	ACTIVE	SOIC	D	8		TBD	CU NIPDAU	Level-3-220C-168 HR

⁽¹⁾ The marketing status values are defined as follows:

ACTIVE: Product device recommended for new designs.

LIFEBUY: TI has announced that the device will be discontinued, and a lifetime-buy period is in effect.

NRND: Not recommended for new designs. Device is in production to support existing customers, but TI does not recommend using this part in a new design.

PREVIEW: Device has been announced but is not in production. Samples may or may not be available.

OBSOLETE: TI has discontinued the production of the device.

⁽²⁾ Eco Plan - The planned eco-friendly classification: Pb-Free (RoHS) or Green (RoHS & no Sb/Br) - please check <http://www.ti.com/productcontent> for the latest availability information and additional product content details.

TBD: The Pb-Free/Green conversion plan has not been defined.

Pb-Free (RoHS): TI's terms "Lead-Free" or "Pb-Free" mean semiconductor products that are compatible with the current RoHS requirements for all 6 substances, including the requirement that lead not exceed 0.1% by weight in homogeneous materials. Where designed to be soldered at high temperatures, TI Pb-Free products are suitable for use in specified lead-free processes.

Green (RoHS & no Sb/Br): TI defines "Green" to mean Pb-Free (RoHS compatible), and free of Bromine (Br) and Antimony (Sb) based flame retardants (Br or Sb do not exceed 0.1% by weight in homogeneous material)

⁽³⁾ MSL, Peak Temp. -- The Moisture Sensitivity Level rating according to the JEDEC industry standard classifications, and peak solder temperature.

Important Information and Disclaimer:The information provided on this page represents TI's knowledge and belief as of the date that it is provided. TI bases its knowledge and belief on information provided by third parties, and makes no representation or warranty as to the accuracy of such information. Efforts are underway to better integrate information from third parties. TI has taken and continues to take reasonable steps to provide representative and accurate information but may not have conducted destructive testing or chemical analysis on incoming materials and chemicals. TI and TI suppliers consider certain information to be proprietary, and thus CAS numbers and other limited information may not be available for release.

In no event shall TI's liability arising out of such information exceed the total purchase price of the TI part(s) at issue in this document sold by TI to Customer on an annual basis.

P (R-PDIP-T8)

PLASTIC DUAL-IN-LINE



4040082/D 05/98

- NOTES: A. All linear dimensions are in inches (millimeters).
 B. This drawing is subject to change without notice.
 C. Falls within JEDEC MS-001

For the latest package information, go to http://www.ti.com/sc/docs/package/pkg_info.htm



KTW (R-PSFM-G7)

PLASTIC FLANGE-MOUNT

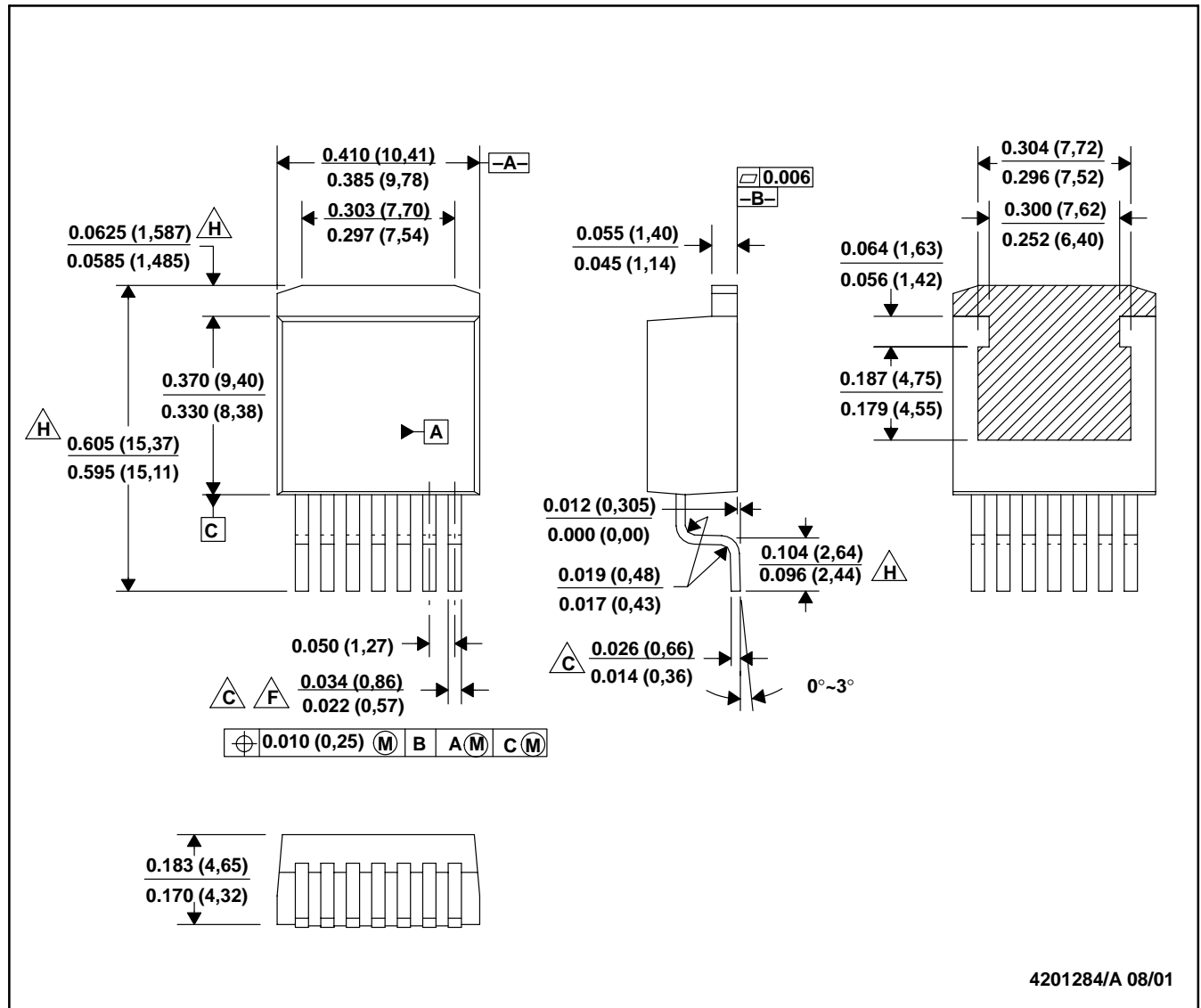

- NOTES:
- All linear dimensions are in inches (millimeters).
 - This drawing is subject to change without notice.
 - $\triangle C$: Lead width and height dimensions apply to the plated lead.
 - Leads are not allowed above the Datum B.
 - Stand-off height is measured from lead tip with reference to Datum B.
 - $\triangle F$: Lead width dimension does not include dambar protrusion. Allowable dambar protrusion shall not cause the lead width to exceed the maximum dimension by more than 0.003".
 - Cross-hatch indicates exposed metal surface.
 - $\triangle H$: Falls within JEDEC MO-169 with the exception of the dimensions indicated.

D (R-PDSO-G8)

PLASTIC SMALL-OUTLINE PACKAGE

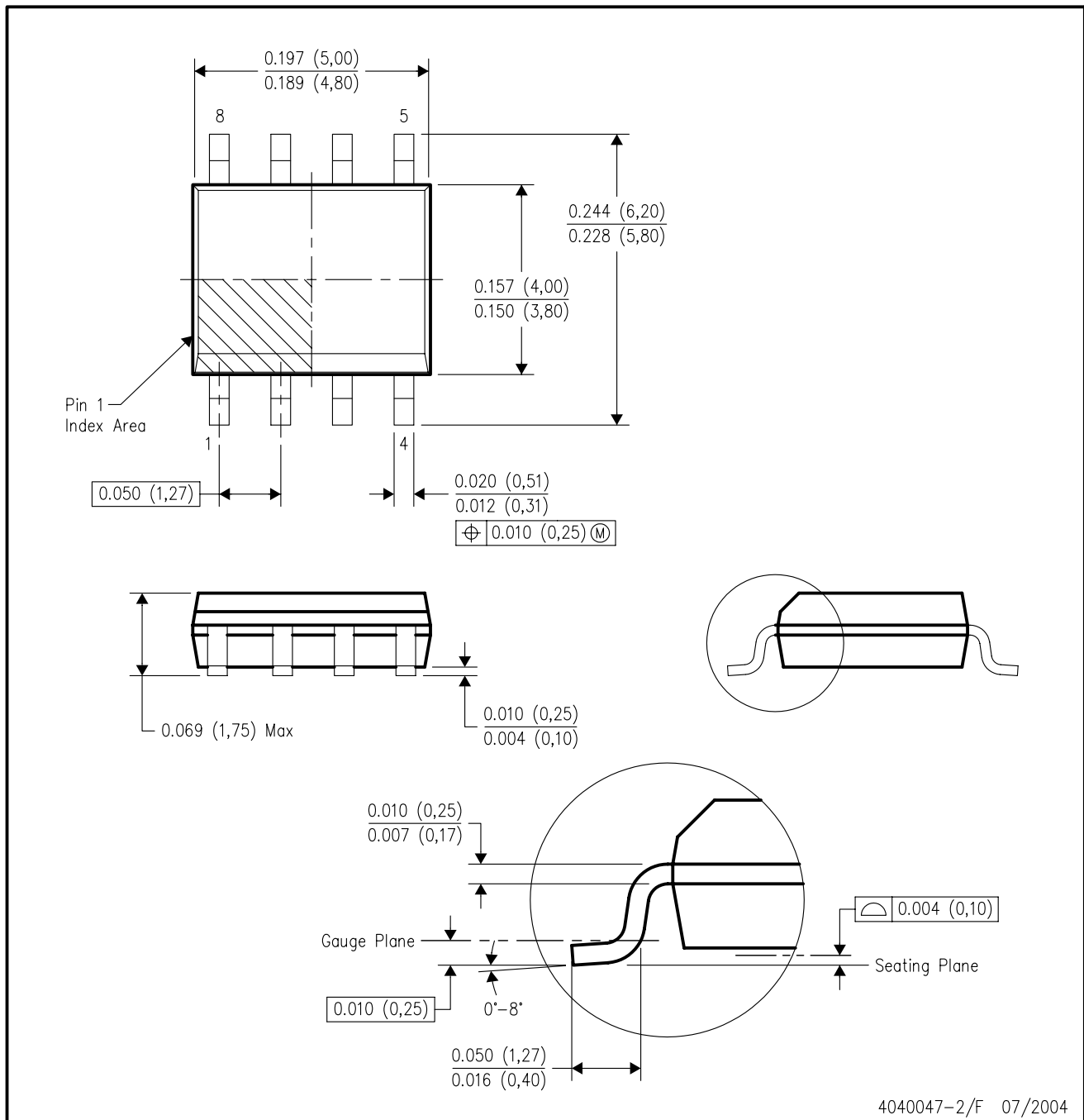

- NOTES:
- A. All linear dimensions are in inches (millimeters).
 - B. This drawing is subject to change without notice.
 - C. Body dimensions do not include mold flash or protrusion not to exceed 0.006 (0,15).
 - D. Falls within JEDEC MS-012 variation AA.

IMPORTANT NOTICE

Texas Instruments Incorporated and its subsidiaries (TI) reserve the right to make corrections, modifications, enhancements, improvements, and other changes to its products and services at any time and to discontinue any product or service without notice. Customers should obtain the latest relevant information before placing orders and should verify that such information is current and complete. All products are sold subject to TI's terms and conditions of sale supplied at the time of order acknowledgment.

TI warrants performance of its hardware products to the specifications applicable at the time of sale in accordance with TI's standard warranty. Testing and other quality control techniques are used to the extent TI deems necessary to support this warranty. Except where mandated by government requirements, testing of all parameters of each product is not necessarily performed.

TI assumes no liability for applications assistance or customer product design. Customers are responsible for their products and applications using TI components. To minimize the risks associated with customer products and applications, customers should provide adequate design and operating safeguards.

TI does not warrant or represent that any license, either express or implied, is granted under any TI patent right, copyright, mask work right, or other TI intellectual property right relating to any combination, machine, or process in which TI products or services are used. Information published by TI regarding third-party products or services does not constitute a license from TI to use such products or services or a warranty or endorsement thereof. Use of such information may require a license from a third party under the patents or other intellectual property of the third party, or a license from TI under the patents or other intellectual property of TI.

Reproduction of information in TI data books or data sheets is permissible only if reproduction is without alteration and is accompanied by all associated warranties, conditions, limitations, and notices. Reproduction of this information with alteration is an unfair and deceptive business practice. TI is not responsible or liable for such altered documentation.

Resale of TI products or services with statements different from or beyond the parameters stated by TI for that product or service voids all express and any implied warranties for the associated TI product or service and is an unfair and deceptive business practice. TI is not responsible or liable for any such statements.

Following are URLs where you can obtain information on other Texas Instruments products and application solutions:

Products		Applications	
Amplifiers	amplifier.ti.com	Audio	www.ti.com/audio
Data Converters	dataconverter.ti.com	Automotive	www.ti.com/automotive
DSP	dsp.ti.com	Broadband	www.ti.com/broadband
Interface	interface.ti.com	Digital Control	www.ti.com/digitalcontrol
Logic	logic.ti.com	Military	www.ti.com/military
Power Mgmt	power.ti.com	Optical Networking	www.ti.com/opticalnetwork
Microcontrollers	microcontroller.ti.com	Security	www.ti.com/security
		Telephony	www.ti.com/telephony
		Video & Imaging	www.ti.com/video
		Wireless	www.ti.com/wireless

Mailing Address: Texas Instruments
Post Office Box 655303 Dallas, Texas 75265